

MOBILE RACKING SYSTEMS

Warehouse systems for more room on less space -
from manual to semi- or fully automated systems

ssi-schaefer.com

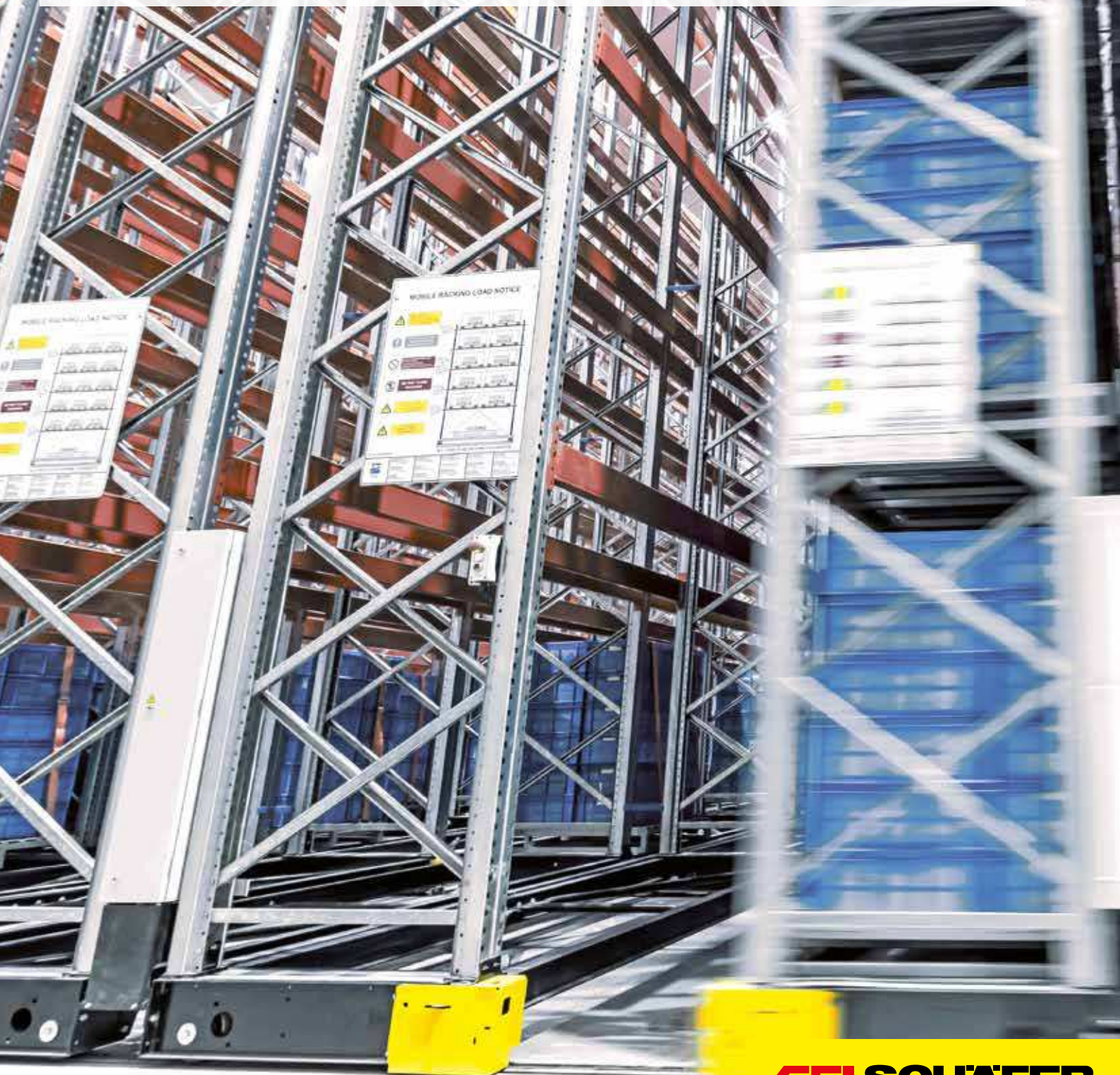

SSI SCHÄFER

MORE STORAGE ON LESS SPACE

Our mobile racking systems not only let you optimize your space requirements, but also free up additional room. The systems offer a maximum amount of flexibility with respect to size and quality of your stored goods, which may vary from extremely large and heavy goods to documents, apparel, small parts, spare parts, tires, or tools.

Our solutions feature the highest quality, various combinations, and an extensive number of adjustment options. A modular concept provides the capability of assembling the system according to customized requirements.

ADVANTAGES OF MOBILE RACKING SYSTEMS

- Increased storage capacity up to 90%
- Space savings of up to 45%
- High efficiency and durability
- Possible combinations with conveying system and Automated Guided Vehicles



EFFICIENT SPACE UTILIZATION FOR OPTIMUM WAREHOUSE LOGISTICS WITH MOBILE RACKING SYSTEMS

Pallet racks in conventional arrangement



Logistical data in comparison	
Total storage area	625 m ²
Of which rack area	223 m ²
Proportion of aisle area	402 m ²
Floor space utilization	36 %
Pallet locations	1,152
Area loss	64 %

Mobile racks for optimized use of space



Logistical data in comparison	
Total storage area	353 m ²
Of which rack area	223 m ²
Proportion of aisle area	130 m ²
Floor space utilization	63 %
Pallet locations	1,152
Area gain	44 %

Mobile racks for the requirement of higher storage capacity



Logistical data in comparison	
Total storage area	625 m ²
Of which rack area	463 m ²
Proportion of aisle area	162 m ²
Floor space utilization	74 %
Pallet locations	2,304
Capacity gains	100 %

MOBILE RACKING SYSTEMS - A CONVINCING COMPLETE SYSTEM



Automatic forklift release

Control cabinet with plain text display

Switchgear cabinet

Rail system see p. 8 - 9 for more info

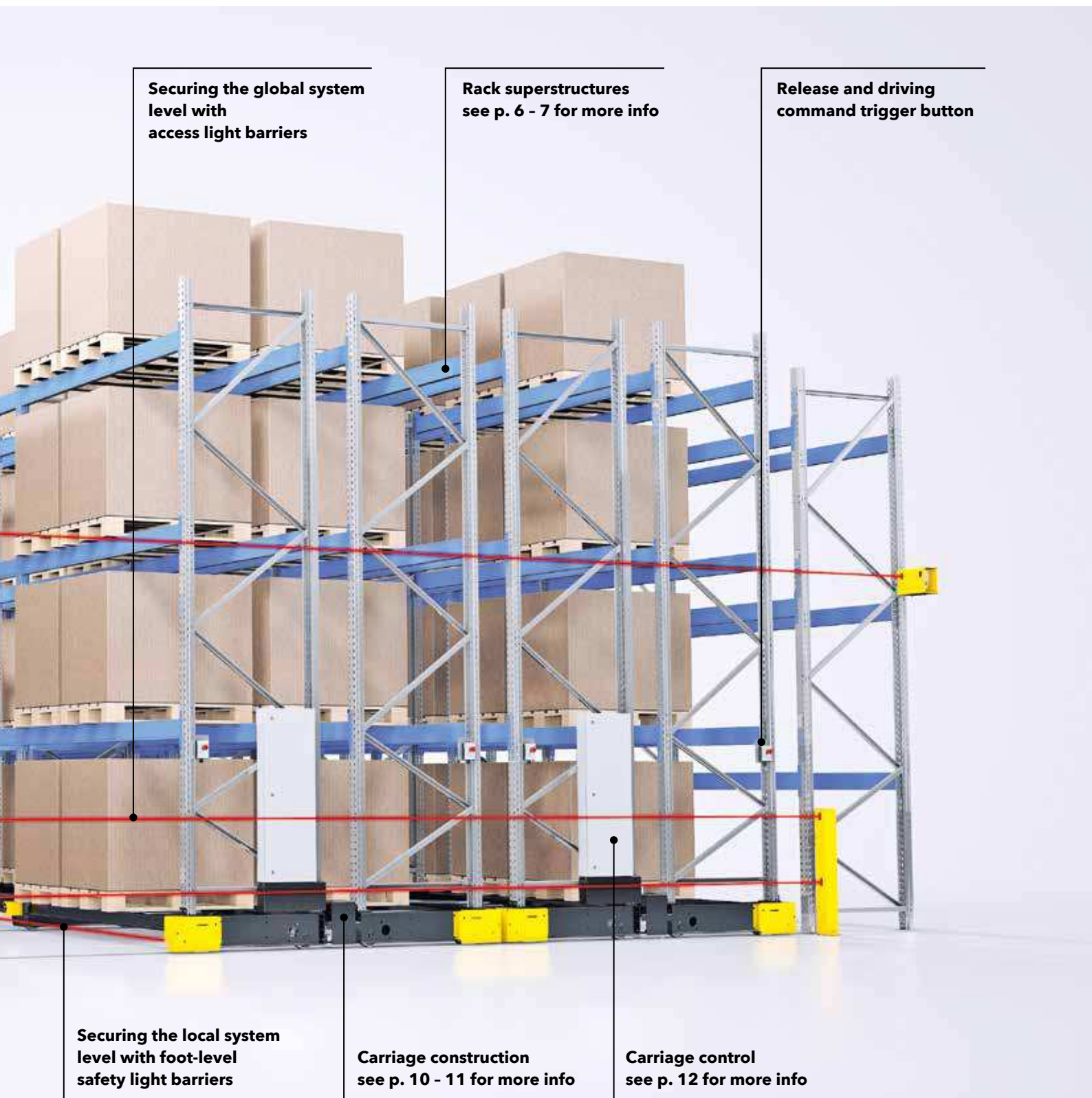

Securing the global system level with access light barriers

Rack superstructures see p. 6 - 7 for more info

Release and driving command trigger button

Securing the local system level with foot-level safety light barriers

Carriage construction see p. 10 - 11 for more info

Carriage control see p. 12 for more info





FLEXIBLE RACKING SYSTEMS FOR LARGE AND HEAVY GOODS

Heavy load racking systems for pallets and oversized goods are designed for the most demanding weight and size requirements of the goods to be stored. The modular construction also allows customized solutions.

Suitable for Use in Cold Storage Environment

Our rack systems, our competence in conveyor technology, and our powerful electric motors combined make our systems the number one choice for use in cold storage warehouses.

Safe Work Environment

The pallet mobile rack systems are equipped with emergency-stop buttons, photoelectric access barriers, manual release systems, proximity sensors as well as safety light barriers. All of these features ensure that our solutions contribute significantly to the smooth and safe working environment in your warehouse.



SYSTEM BENEFITS

- Increased storage capacity (up to 90%), space savings of up to 45%
- Reduced operating and real estate costs as a result of excellent system space utilization (surface area utilization of up to 80%)
- Maximum storage density
- Increased energy efficiency
- Direct access to pallet locations prevents unnecessary and time-intensive relocation
- High throughput
- Option to connect to the warehouse management system
- Earthquake-proof design

Mobile rack systems can also be utilized in connection with Automated Guided Vehicles. The SSI SCHAEFER fleet includes many innovative solutions.

They allow a barrier-free network of different warehouse and work areas, can be customized to individual customer requirements, and flexibly expanded.

INNOVATIVE RAIL DESIGN

Generally, all of our SSI SCHAEFER rack systems can be set down on rail systems. The rack system is defined by the stored goods. Pallets, containers or barrels, for example, are stored on pallet racks. Long and bulky parts are ideally stored with cantilever racks.

The principle:

The carriages are driven with the aid of a single motor drive along parallel rail embedded in the floor, so only a single operator aisle is needed for quick access to all stored goods.

PRECISION WORK DURING INSTALLATION

- Levelling mounting brackets every 600 / 1,000 mm
- Installation support from experienced supervisors worldwide
- Installation reports for the security of the customers and subcontractors

For installation in multi-level floors

- For existing floors
- For load-bearing ceiling constructions
- In milling grooves

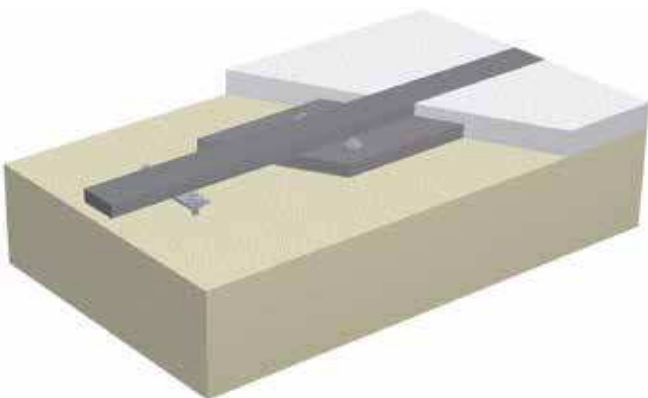

For installation in single-level floors

- For new construction and cold storage warehouses
- For single layer industrial floors

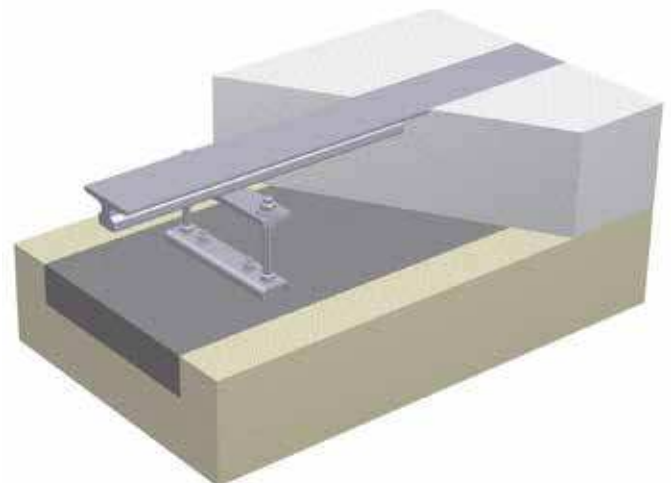

QUALITY CRITERIA

The form and quality of the rail system have a decisive influence on the durability of mobile racking systems. The A45 rail profile made of high-strength steel with high inherent stiffness fits perfectly into the concrete and thus ensures a long service life.

A45 guide rail

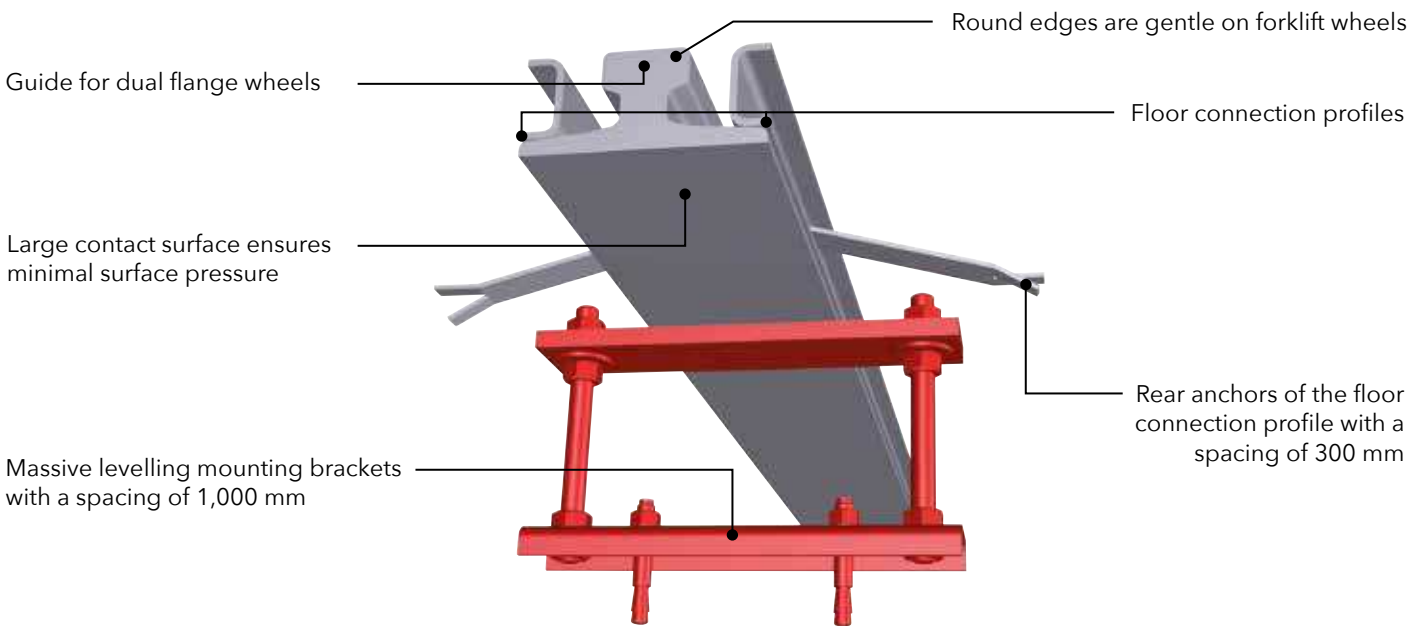

Running rail A45

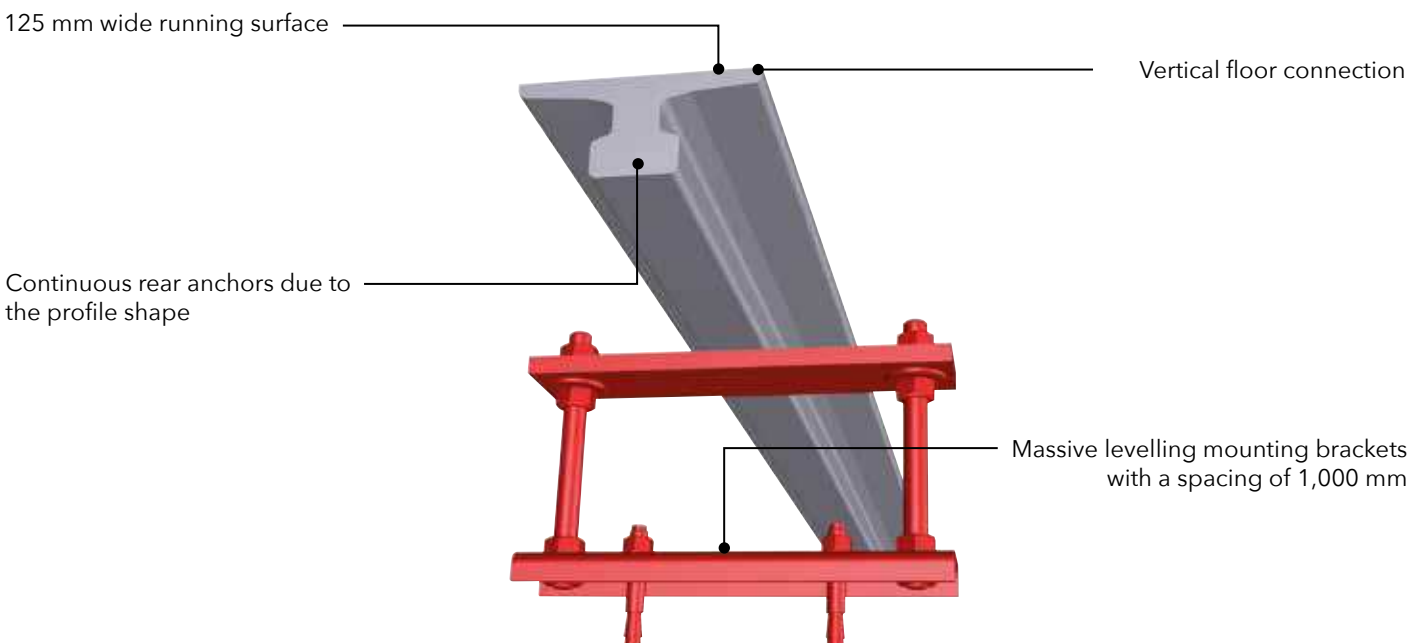

AHEAD OF THE TIMES - INNOVATION AND ENGINEERING OF A NEW DESIGN CONCEPT

Mobile bases cover
separate covers optional

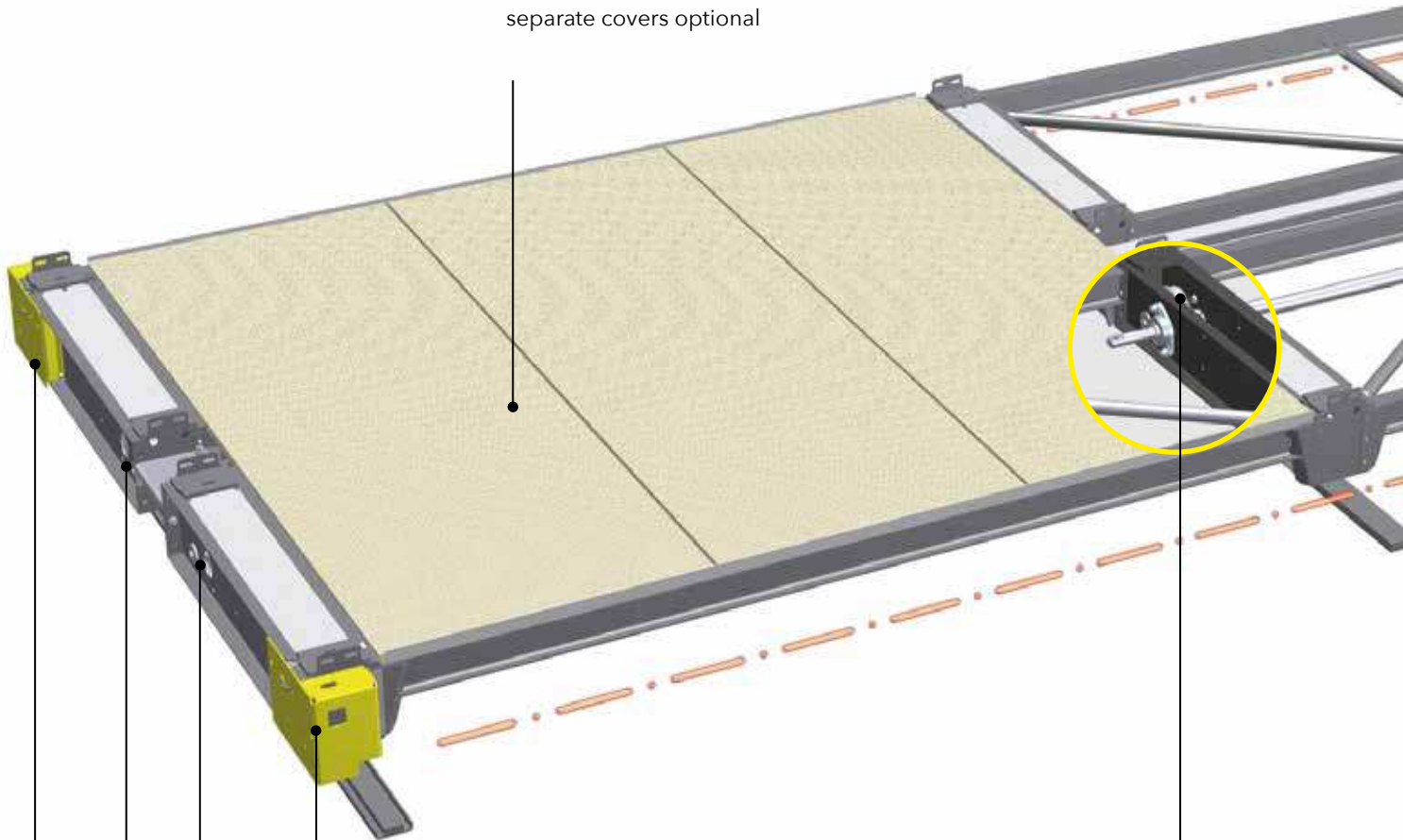

Four-wheel travelling mechanism

Advantage for structure planning:
Four wheels reduce the loads
pressing on the ground.

Bearing design

Absolute wear reduction:
Four raceways with deep groove ball
bearings (closed version) prevent
unilateral bearing load.



Guide frame:

Safe dual
wheel flange



Running wheel:

Cambered
running wheels



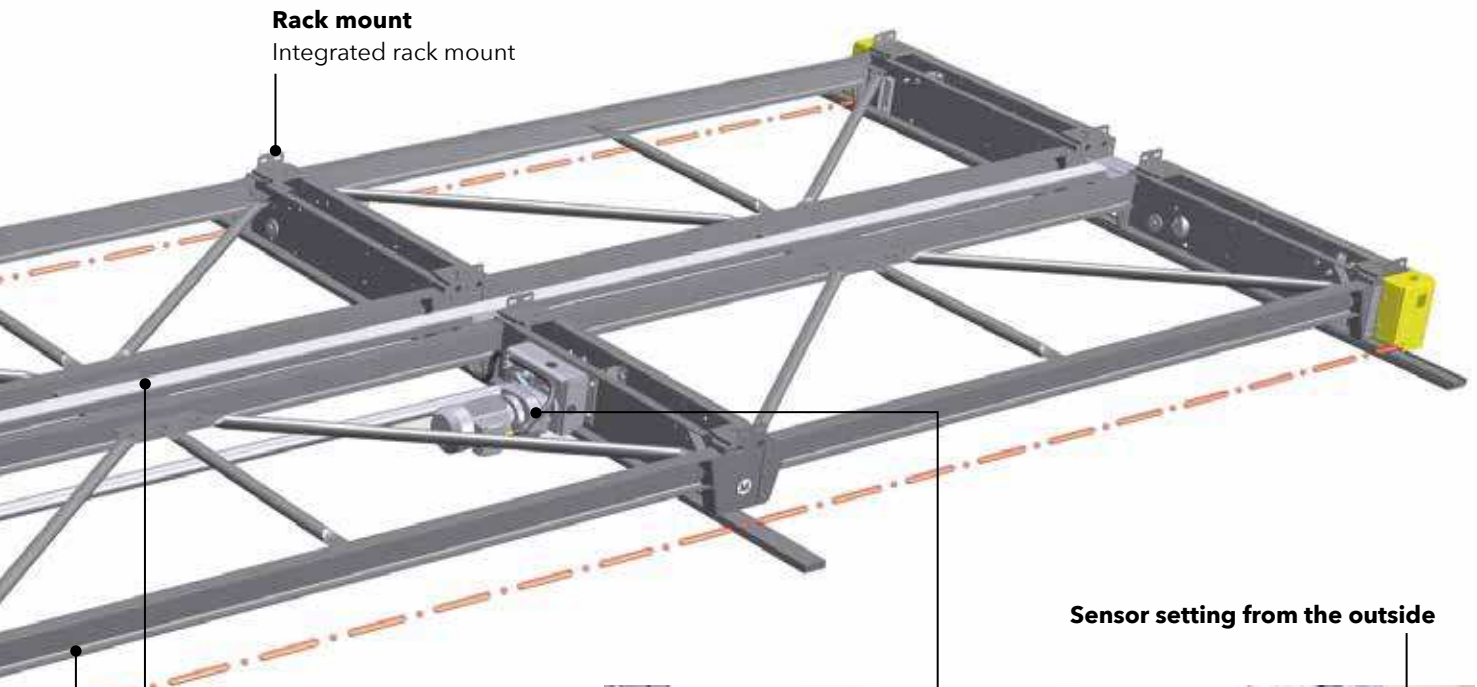

Rack mount

Integrated rack mount

Sensor setting from the outside

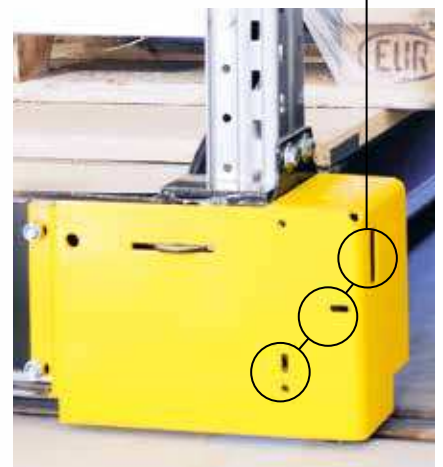
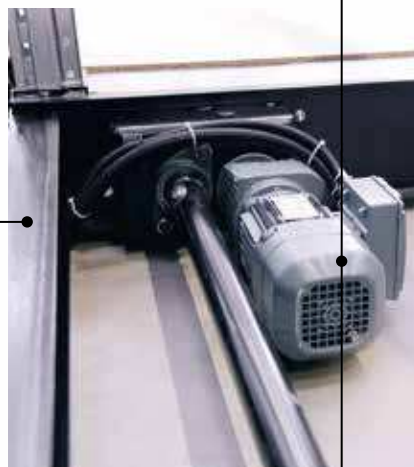

Key component

Ruggedly welded center beam:
Torsion-resistant and dimensionally accurate.

Electric drive

Powerful drive concept:
Two gear stages in direct gear and coordinated engine control.

Component protection

Effective component protection:
Light barriers and proximity sensors protected under rugged cover.

Robust

Hot-rolled IPE beams:
Guarantee stability, even in rough forklift operation.

INTELLIGENT SYSTEM CONTROLS

Every SSI SCHAEFER mobile racking system is equipped with a modern programmable logic control (PLC). Among other things, it monitors the safety of the global system level using photoelectric access barriers and the local system level with a foot-level safety light barriers on each mobile carrier, ensuring safe system operation. An interface allows the connection to an upper-level warehouse management system.



STANDARD OPERATING FUNCTIONS

- The safety technology modules are integrated into the standard control unit for flexible and customized safety of the areas
- Emergency stop button at every operating station
- Manual release system and rack movement executed via a control button on each rack
- Manual emergency operation feature
- Permanent system status display via touch screen graphic display
- Travel time and drive monitoring
- Control of the displays elements
- Operating hours counter



OPTIONAL COMPONENTS



Remote Control for Rack Aisles

- Wireless remote control with graphical display
- The rack aisle to be opened is selected with a push of a button on the carriage or on the remote control in the forklift
- Time savings thanks to the coordinated movement of the mobile racks and the forklift
- Integrated automatic stacker release
- Dynamic aisle change during operation



Control Options - Distance Controls

- For the formation of picking aisles
- As recirculation switch in the cooling / freezing area
- As an access for firefighting



Control Option - Aisle Lighting

- Reduced energy consumption with lighting pilot control
- The light sources must be arranged in parallel to the mobile rack lines



Mobile carrier cover

- Chipboard
- Steel or mesh decks

Other options

- Forklift detection
- Rear system operation
- Interface for warehouse management system
- Optical travel warning
- Remote access / remote diagnostics
- Acoustic advance travel warning
- Touch control
- Synchronization control



EFFECTIVE FIRE PROTECTION

Our mobile racks can also be equipped with movable sprinklers to ensure effective fire protection. The sprinkler line connection can be flexible or via scissor feed joints. The mobile racking systems can be combined with all fire protection systems, regardless of the manufacturer.





KLOOSTERBOER DELTA TERMINAL: MAXIMUM OCCUPATION DENSITY

The Kloosterboer Group is a logistics supplier specializing in temperature-controlled storage and distribution of food products. SSI SCHAEFER installed a mobile pallet racking system to expand the capacity of a cold storage warehouse in Rotterdam, The Netherlands. The growing market demand for smaller batch sizes with more varieties that can be ordered by the pallet was the deciding factor for the choice of this warehouse solution.

In addition to the ideal space utilization, it guarantees access to storage spaces at any time, ensuring excellent storage density and optimized storage based on the FIFO concept.

The plant spans an area of 9,600 m² and features a large shipping area, a veterinary inspection area, 28 inflatable door seals, and eight cells for cooling and freezing applications. The cells offer a total warehouse capacity of more than 10,000 pallets, which can be stored in the mobile rack at a height of up to 11 meters. The electric shuttle cars can each move up to 320 tons. The system is equipped with forklift detection. The aisle release is controlled via WMS.



ARCTIC PROCESSES AT GRUPO VIBRA IN BRAZIL

How can meat products arrive quickly and flawlessly at the customer's location without interrupting the cooling chain? The intralogistics specialist SSI SCHAEFER solved this problem for its Brazilian customer Grupo Vibra. A new mobile pallet rack system is the heart of the solution and imperative for compliance with hygiene regulations.

A new warehouse hall was built specifically for the project. In consultation with the customer, the mobile rack system was installed in an area of 1,500 m², customized to customer specifications according to the stored goods and storage

quantities as well as turnover and throughputs. Five pallet levels, 3,500 pallet locations, and 28 pallets per hour. The key figures speak for themselves: The new solution offers 28 double cycles per hour. Warehousing and picking of the goods is now performed within the cooling area with no interruptions in the cooling chain. This is made possible by two aisles in the mobile rack system designed especially for order picking. In addition, two buffer zones in the cold storage warehouse ensure fast storing and retrieval of goods. This means, space shortages and complicated interim storage of meat products outside of cooling areas are a thing of the past.

MOBILE SHELVING FOR LIGHT AND MEDIUM-WEIGHT LOADS

Whether documents, clothing, small parts, spare parts, tools, or other light to medium rack loads - with its mobile shelvings, SSI SCHAEFER offers the ideal warehouse solution for light-weight to medium-weight loads.

Innovative Technologies:

Depending on the stored goods and requirements, our mobile shelvings are offered with the following features:

- Crank drive for rail systems: Because the rails are anchored in the floor, this type is also suitable for high and narrow construction.
- Crank drive for non-rail systems: Because the existing floor does not need to be modified when installing this system type, the non-rail solution can be easily installed on almost all existing surfaces and is also ideally suited for special floors or heated floors.
- Electric drive and RFID technology: With this option, we combine the versatility of the mobile shelving with the benefits of modern RFID technology. The result is a shelving system that can be operated safely and easily and is suitable for a wide range of applications in the office, workshop, or archive areas.

SYSTEM BENEFITS

- Space gain: 40% less space than stationary shelves lines or space for 85% more storage volume on the same surface area
- Optimized space requirements, additional space on the free surface
- Optimized and reduced transit times in internal workflows
- Higher efficiency due to fewer shelving aisles
- Three different designs
- Highest quality
- High flexibility with modular expansion options and different combinations





MOBILE RACK EMX FOR TIRE STORAGE

A tire warehouse is only efficient if it is well adapted to the local conditions. Benefit from our space saving, flexible, and safe EMX mobile rack system.

Our mobile rack systems for tires and wheels include conventional tire or cantilever racks mounted on carriages and moved parallel to each other using a motorized drive. As the rack is moved along rails, only the aisle needed is opened.

This solution ensures maximum economic efficiency because of the reduced space requirement in the workshop or in the warehouse.

SYSTEM BENEFITS

- Almost twice the warehouse capacity as static warehouse solution on the same area
- All wheel and tire sizes up to 800 mm diameter can be stored
- Wheels with spikes can also be stored
- Compliance with all applicable health regulations, because the wheels, some of which might be difficult to install, do not need to be manually lifted by one person
- Thanks to carriers that can drive underneath the rack, the wheel stacks can be quickly and safely stored in and out from the ground using a forklift
- Reduced operating and real estate costs as a result of excellent system space utilization
- Equipped with state-of-the-art PLC control unit
- Carrier loads up to 50 t, carrier length up to 25 m
- Modular expansion option
- High flexibility, quality, and durability
- Different combinations
- Comprehensive expertise



SIX REASONS FOR CHOOSING SSI SCHAEFER:

- **Stability:**

As a financially independent family business, SSI SCHAEFER is committed to long-term solutions. You can trust that our team of experts will be there for you today, tomorrow and in years to come.

- **Efficiency:**

SSI SCHAEFER solutions are scalable and able to grow with your business. You can always upgrade or retrofit.

- **Quality:**

As a systems specialist and original equipment manufacturer, SSI SCHAEFER provides tailor-made and high-quality solutions from a single source, specifically designed to meet your challenges.

- **Reliability:**

Thanks to our worldwide Customer Service & Support network, SSI SCHAEFER ensures smooth operation of your system, both during and after installation.

- **Know-how:**

SSI SCHAEFER solutions are always up-to-date with the latest technological standards and can be easily integrated into an existing (IT) landscape.

- **Internationality:**

As a global organization, SSI SCHAEFER has local offices worldwide. With over 70 operative subsidiaries, our team of experts speak your language.

[ssi-schaefer.com](https://www.ssi-schaefer.com)

0082_022019_h © SSI SCHÄFER

Printed in Germany. We assume no liability for typographical errors. We reserve the right to make technical changes to all products shown in this document.

SSI SCHAEFER